



This product meets a stringent set of our company's internally defined sustainability standards

SFC SUPERFLOW COMBI



COMBI

DUAL CONDENSING
COMBI BOILER
SFC 199-1



Unique WIRELESS CASCADE Feature

The Superflow™ SFC 199-1 now includes an innovative wireless cascade feature which allows up to 8 units to operate together for instances where a single Superflow™ unit is not large enough. Create a cascade system using multiple SFC 199-1 units to meet your domestic hot water and space heating needs with the added benefits of greater efficiency and redundancy. The Superflow™ wireless cascade system is very easy to set up and flexible enough for your most demanding applications.

- Wireless communication means cascade system setup is as simple as enabling the built-in cascade function on up to 8 units and connecting the system sensor. No communication cables required.
- Cascade multiple Superflow™ units for any DHW and/or space heating application.
- Wireless communication provides the ultimate in cascade system redundancy. The cascade system continues to operate during maintenance or repair of a cascaded unit.

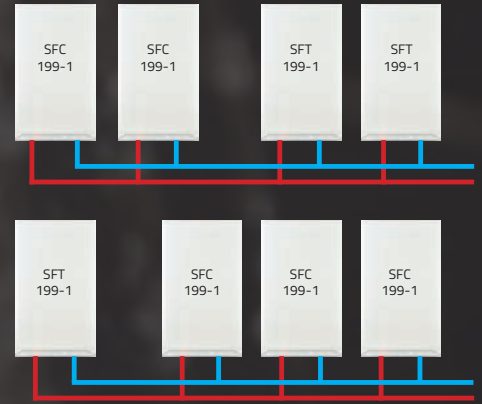

Wireless cascade multiple configurations up to 8 units.*

INNOVATION

Easy Maintenance

1. Pump (ECM)
2. Exhaust Fitting
3. Burner Fan
4. Heat Exchanger
5. Rear Flue Duct
6. Gas Valve
7. Touch Pad Control
8. Condensate Trap
9. Air Intake
10. Cover
11. Inlet Gas Line
12. Outlet Gas Tube



5 Moving Parts

Fan, Bypass Valve, Pump, Gas Valve, and Damper

The SFC Superflow™ contains cutting-edge, solid-state electronics to control its gas valve, fan, and ignition. By doing so, we've succeeded in reducing the number of moving parts, made service simple, and increased reliability.

*Diagrams and images for visual representation only. Consult Installation & Operation Manual for further information.



The Only Fully Condensing Combi Boiler On The Market

You expect your combi boiler to provide enough hot water for both your kitchen and bathroom, as well as enough heat to make your home cozy and warm. Our SFC Combi is designed to do just that. Whatever your exact heating and hot water requirements may be, our SFC Combi boiler is sure to be a perfect match for you.



SIMPLE

Mount > Connect > Plug In > Enjoy endless heat and hot water

- 2 independent copper waterways embedded in a cast aluminum block
- A total of 5 moving parts - Unparalleled in the industry (*Fan, Pump, Bypass Valve, Gas Valve, and Damper*)
- Illuminated touchscreen control display panel
- Factory installed domestic water strainer saves installation time
- 2" venting up to 65 ft. and 2" vent adapter
- Standard pipe size connections
- Extended pipe fittings

RELIABLE

- 30-year track record, 2 million installations worldwide
- Innovative state of the art electronic control
- Compatible with standard Propylene Glycol
- Built-in bypass valve to prevent temperature fluctuations (SFC 199-1)
- No need for a 3-way valve or secondary DHW plate heat exchanger
- Will accept a 0-10 VDC signal

EFFICIENT

- 95% AFUE with full ASME-rated heat exchanger
- Wireless cascade up to 8 units (SFC 199-1). Multiple domestic and space heating cascade configurations available.
- Packaged with a high efficiency variable speed pump (ECM)
- Outdoor reset technology increases efficiency by lowering the water temperature automatically
- Advanced modulating temperature control



SFC - COMBI

Dimensions

PIPING CONNECTIONS	DIMENSIONS
A Exhaust outlet	2" Schedule 40 PVC
B Combustion air	2" Schedule 40 PVC
C Cold dom. water connection	3/4" Male NPT
D Hot dom. water connection	3/4" Male NPT
E Heating water inlet (return)	1" Male NPT
F Heating water outlet (supply)	1" Male NPT
G Gas inlet	3/4" Male NPT
H Condensate outlet	3/4" Hose
I Control wiring passage	7/16" Rubber Plug

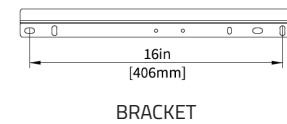
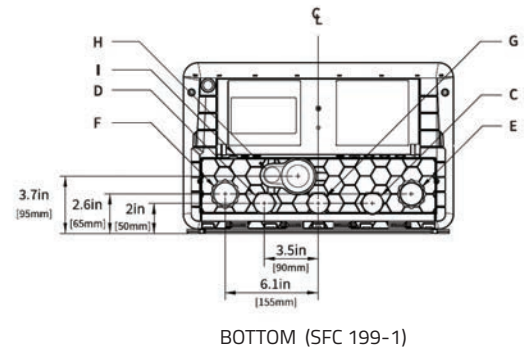
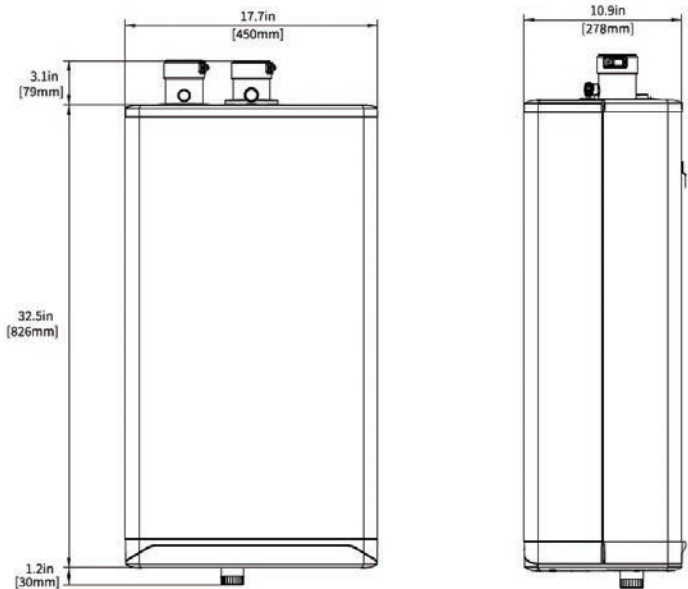
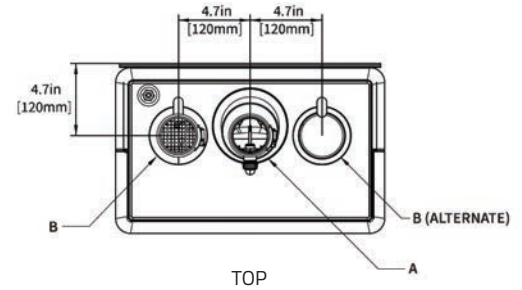

Touch Panel Control Indicators

The **SFC Superflow™** controller functions as an interactive touch-sensitive panel with buttons that light up, showing indicators such as numbers, icons, or letters. Some of these lit indicators signify boiler operational status. Other indicators enable you to program the boiler.

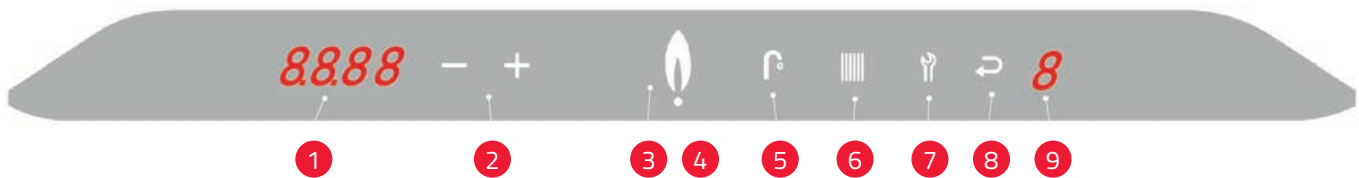

TOUCH PANEL	FUNCTION	TOUCH PANEL	FUNCTION
1. Numerical Display	Main display	6. Radiator	Space heating indicator
2. Plus & Minus	Temperature adjustment	7. Wrench	Service / Reset
3. Flame	Burner ON indicator	8. Return Arrow	Enter / Save
4. Dot	Power ON indicator	9. Numerical Display	Service display
5. Faucet	DHW indicator		

ALL THE HEAT
AND HOT WATER
YOU WILL EVER NEED



INNOVATIVE Labyrinth Heat Exchanger Design

Our SFC SUPERFLOW™ utilizes our patented, tried-and-tested heat exchanger technology that incorporates a fully integrated copper coil, ensuring maximum heat transfer and minimal heat loss.

The cold water supply flows directly through the heat exchanger, condenses flue gasses fully, and extracts as much heat as possible.



SFC - COMBI

Technical Information



SPECIFICATIONS	SFC 199-1
CSA Input (Natural Gas or Propane) - MBH	28.5-125
CSA Input (Natural Gas or Propane) - KW	8.4-36.6
CSA Output - MBH	27.1-111
CSA Output - KW	7.9-32.5
DHW - CSA Input (Natural Gas or Propane) - MBH	28.5-199
DHW - CSA Input (Natural Gas or Propane) - KW	8.4-58.3
A.F.U.E.	95%
Min. Gas Pressure (Nat. Gas or Propane) - Inch W.C.	4
Max. Gas Pressure (Nat. Gas or Propane) - Inch W.C.	14
Power (120Vac/60Hz) - Watts at Full Fire w/ Internal Pump	120
Weight (empty) - lbs/Kg	84/38
Pressure Vessel Water Content - USG/Liters	0.19/0.72
Max. Boiler Flow Rate - GPM/LPM	12/45.4
Min. Boiler Flow Rate - GPM/LPM	2/7.6
Max. Operating Pressure - Space Heating Coil - psig	43.5
Max. Operating Pressure - Domestic Hot Water Coil - psig	150
Min. Water Pressure - psig	8
Approved Installation Altitude - ASL	10,000 ft
Ambient Temperature - Low (°F/°C)	32/0
Ambient Temperature - High (°F/°C)	122/50
Max. Relative Humidity (Non-Condensing)	90%
Min. Water Temperature - Space Heating (°F/°C)	51/10
Max. Water Temperature - Space Heating (°F/°C)	194/90
Min. Water Temperature - Domestic Hot Water (°F/°C)	105/40
Max. Water Temperature - Domestic Hot Water (°F/°C)	149/65
Min. Flow Rate to Activate DHW Heating - GPM/LPM	0.5/1.9
Max. Flow Rate DHW Heating - GPM/LPM	7/26.5
Max. Equivalent Vent Length 2" (each side)	65' *
Max. Equivalent Vent Length 3" (each side)	120'
DHW Delivery: At 67°F/37.2°C Temperature Rise - GPM/LPM	5/18.9

SURFACE	DISTANCE FROM COMBUSTIBLE SURFACES	RECOMMENDED DISTANCE FOR INSTALLATION AND SERVICE
Front	2"	24"
Rear	0"	0"
Left Side	1.5"	6"
Right Side	4"	6"
Top	2"	24"
Bottom	8"	24"



VENTING	MAXIMUM EQUIVALENT LENGTH
Schedule 40 PVC, CPVC, or PPs	
2"	65' *
3"	120'
2" or 3" 90° Long Sweep Vent Elbow	Allow 5 equivalent feet
2" or 3" 90° Short Sweep Vent Elbow	Allow 8 equivalent feet
2" or 3" 45° Vent Elbow	Allow 3 equivalent feet
PPs	
PPs 87-90' Elbow	Allow 8 equivalent feet
Flex PPs	
3" PPs Flex	35' Actual (Equivalent = Actual x 1.4)

* Approximate input derate of 10-16% at 2" maximum vent length.



CO₂ IMPACT SCORE

Choosing this product instead of a minimum efficiency alternative offsets CO₂ emissions equivalent to planting this number of trees over the product's lifetime. The CO₂ Impact Score is internally calculated on a proprietary point system based on a typical product lifetime and does not denote a third party certification/seal. See website for further information.

IBC®

sales@ibcboiler.com ■ www.ibcboiler.com
Toll Free: 1-844-HEAT IBC / 1-844-432-8422

All information contained in this brochure is subject to change without notice. Due to clerical error, regulation change or product development please confirm all information with IBC.

900-349 (R1) 12.01.22